

# Type-40



### DESCRIPTION

Marsh Bellofram's General Purpose Type 40 Pressure Regulator is a reliable precision unit designed for instrumentation and general purpose use.

Test data for the Type 40 regulator shows excellent performance characteristics compared with those of similar units presently on the market. The Type 40 regulator is generally superior in regulated pressure vs. flow, forward-to-reverse flow offset, supply pressure sensitivity, repeatability and stability.

Ruggedly designed and constructed, the Type 40 has housings of diecast aluminum. Every regulator is finished with vinyl paint (which resists scratching, weathering and other physical abuse) and is pressure and leak tested prior to shipment from the factory. Careful design and quality materials throughout assure long, trouble-free operation in the most difficult industrial environments. A rubberized, soft-seat valve stem provides positive shut-off and "forgives" dirt or other foreign matter. An aspirator maintains downstream pressure and compensates for droop when high flow occurs. The gauge port is convenient for gauge installation and can also be used as an additional full flow outlet.

The Type 40 regulator has a 60-mesh 304 stainless steel screen to block foreign particles from entering the output stream. The design of these regulators is especially well suited to pilot-operated controllers and instruments, as well as applications such as air chucks, air spray guns, air cylinders and actuators, and a wide range of industrial pneumatic systems and equipment.

### FEATURES

- Superior regulation characteristics
- Rugged, corrosion resistant construction
- Low cost
- Excellent stability and repeatability
- Self-relieving
- Low droop at high flow
- Several mounting options

### SPECIFICATIONS

Sensitivity	1" (2.5 cm) Water Column
Flow Capacity @ 100 psig (6.9 BAR) Supply & 20 psig (1.4 BAR) outlet	20 SCFM (566 LPM)
Effect of Supply Pressure variation (25 psig/1.7 BAR) on Outlet Pressure	Less than 0.2 psig (0.01 BAR)
Exhaust Capacity 5 psig (0.35 BAR) above set point	0.1-0.45 SCFM Typical 2.8 - 12.7 LPM
Max Supply Pressure	250 psig (17.2 BAR)
Effect of Changes in Flow on Regulated Pressure (100 psig / 6.9 BAR Supply)	2 psig over flow of 10 SCFM / 283 LPM (0-30 psig / 0-2.1 BAR range 1/4" NPT, 20 psig / 1.4 BAR set point)
Output Pressure Ranges	0-30 psig (0-2.1 BAR) 0-60 psig (0-4.1 BAR) 0-120 psig (0-8.3 BAR)
Total Air Consumption @ Maximum Output	6 SCFH (2.8 LPM)
Port Size	1/4" NPT, BSPT
Materials of Construction	Body: Diecast aluminum with vinyl paint Adjusting Screw: Plated steel Trim: Plated steel, brass, acetal resin Diaphragm: Buna-N elastomer and polyester fabric Knob: Phenolic Plastic (option) Spring: Music wire
Tamper Proof Cover	Optional
Mounting Options	Pipe, Panel or Bracket

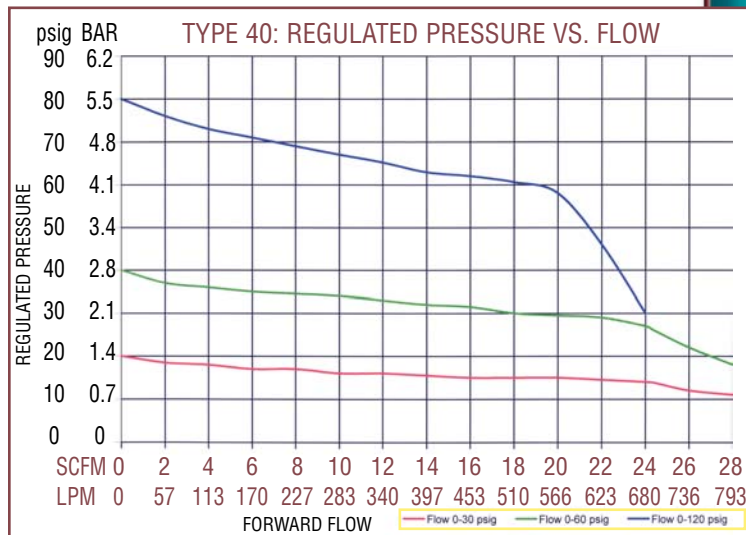

## PART NUMBERS

	Part Number	Port Size (NPT)	Set Point Range	
			BAR	psig
T-40	960-064-000	1/4	0-2.1	0-30
	960-065-000	1/4	0-4.1	0-60
	960-066-000	1/4	0-8.3	0-120

## OPTION ORDERING MATRIX

Replace last three digits of part number with digits from table below.

OPTION	1	2	3	4	5	6	7	8	9	10	11
1 Fluorocarbon Pintle	001	021	031	041	051	061	071	081	091	101	111
2 Non-Relieving		002	032	042	052		072	082	092		112
3 Knob			003	043	053	063	073	083		103	113
5 Epoxy Coating					005	065	075	085	095	105	115
6 Tapped Vent						006	076	086	096	106	116
7 Mounting Bracket							007	087	097	107	117
8 Pressure Gauge								008	098	108	118
9 Tamper-Resistant Cover									009	109	119
10 Soft Relief Seat										010	110
11 Fluorocarbon Diaphragm											011

To order BSPT threads (including the gauge port) add "BSPT" to end of part number.

### FLUOROCARBON PINTLE

A special elastomeric pintle used where elements in the supply air, such as flame retardant synthetic lubricants, are particularly destructive to ordinary pintle material.

### NON RELIEVING

Used in applications where it is desirable to relieve pressure downstream of the regulator, for some constant flow applications, and where the gas flowing through the regulator must not escape at the regulator. Non-relieving regulators should not be used for low or no flow applications.

### CORROSIVE RESISTANT EPOXY FINISH

An epoxy paint applied to the body and bonnet of the regulator exterior surfaces to provide increased corrosion resistance.

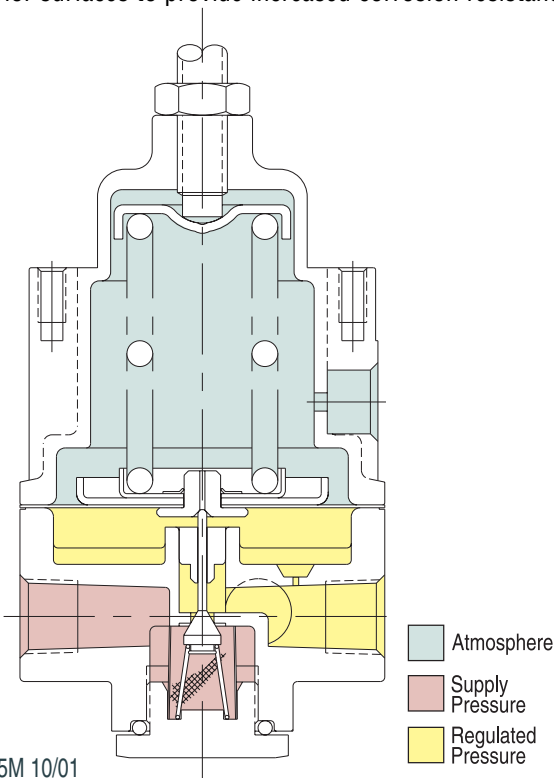

## DIMENSIONAL DRAWING

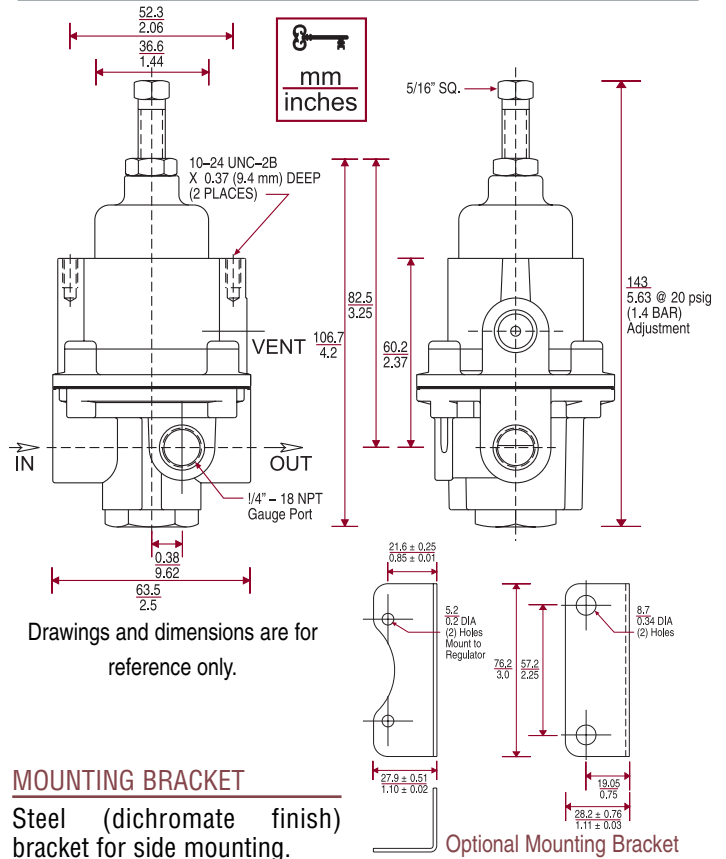

### MOUNTING BRACKET

Steel (dichromate finish) bracket for side mounting.

### KNOB

Option to replace the square head pressure adjusting screw.

### TAPPED VENT

Allows installation of plumbing to capture exhaust air.

### PRESSURE GAUGE

Dual scale 2 in. (50.8 mm) gauges. Ranges include 0-30 psig (0-200 kPa), 0-60 psig (0-400 kPa), 0-100 psig (0-700 kPa) and 0-160 psig (0-1100 kPa). When specified with regulator, the correct range will be supplied. For NPT versions only.

### TAMPER PROOF COVER

An aluminum tubular cover placed over a slotted head adjusting screw and screwed onto the bonnet of the regulator with a wrench. Prevents ordinary hand adjustments.

### SOFT RELIEF SEAT

Used in applications where it is desirable to reduce the standard bleed rate from 6 SCFH [0.17 m<sup>3</sup>/hr] to less than 0.1 SCFH [0.003 m<sup>3</sup>/hr].

### FLUOROCARBON DIAPHRAGM

Diaphragm as well as all seals are made of fluorocarbon elastomer to prevent deterioration from elements in the air supply, such as flame retardant synthetic lubricants normally destructive to standard Nitrile material.

